



Installation Manual

1400 Mounting Platform with Catch-and-Click™ Brackets

Version: 02

MOUNTING PLATFORM:

- **Type A**

APPLICABLE VEHICLE:

- **Isuzu DMax DC MY19 3rd Gen.**

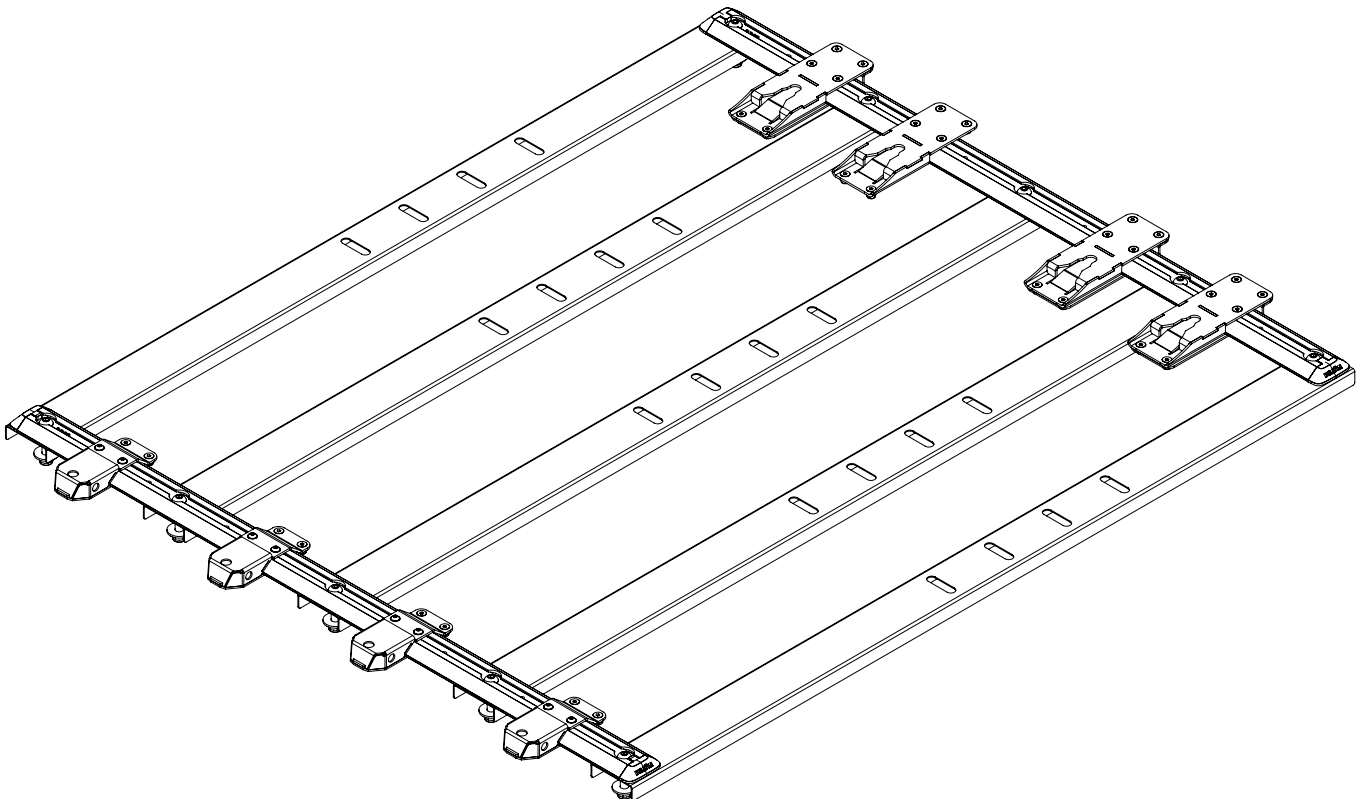

Important Information:

- This Installation Instruction Manual is for the accurate, safe and secure attachment of the 1400 Mounting Platform, and Catch-and-Click™ Brackets to the vehicle.
- Open all kits to check that all parts are present.
- Follow all assembly steps in this Instruction Manual.
- Do not skip steps.
- Do not leave out any fastener components from the installation steps.
- It is recommended to review the vehicle and crosscheck before making any modifications. Check to avoid damaging critical vehicle components beneath the ute tub bed before drilling pilot holes or larger through holes.
- Aftermarket tub-liners can vary significantly between vehicles of the same model. The KUFU Mounting Platform should be securely attached to the steel floor of the ute tub. Removing some of the tub liner material allows space needed to raise and level the Mounting Platform above different liner profiles. Follow this manual to remove the tub-liner around the bolt locations to allow for a level and safe installation.
- Use Spacer Disc parts provided to create a level installation.
- Tub-liners and roller-covers can remain in the ute tub. However, please check to ensure the KUFU Drawer System to-be installed is suitable and will not interfere with these types of accessories.

For example: 280mm and 460mm height drawers and any spacer discs required will interfere with most roller-covers. Please double check the available ute bed height before proceeding with the installation.

Mounting platform heights with no spacer disc:

Type A = 23mm

Type B = 23mm

Type C & MC = 15mm.

- Depending on the tub and clearances required – spacer discs maybe required, which will increase the overall drawer height.
- Reference installation manual step 14 for spacer disc size to calculate overall drawer height when installed.
- All care is taken to provide spacer disc sizing, however due modifications or other aftermarket products, such as tail gate limit straps, struts and covers and tub liners, spacer discs may need to be increased or decreased to clear openings and fit under roll tops
- Some ute tubs have different supporting channels beneath the tub floor, these run laterally across the tub. If the pilot holes and subsequent through holes are positioned on top of these channel areas, longer bolts and crush tubes may be required to support the tightening of fasteners to secure the Mounting Platform without crushing the channel of the ute tub.
- It is recommended to inform the insurance provider for the vehicle of any modifications additions or accessories added to the vehicle, these may affect the ability to make claims depending on the level and or type of cover.
- The KUFU Drawer System and associated Mounting Platforms and Bracket Parts are designed for repeated use. However, wear and tear will occur due to the nature of different materials in the assemblies and installations.

STEP 1 - Installation Preparation:

1. Remove all unattached items from the ute bed.
2. Clean the ute bed.

STEP 2 - Tools Required:

- Hex Drive or Allen Key Set
- Socket Set or Spanner Set
- Powered Drill
- Drill Bits up to 10mm
- Marker - Not black
- Utility Knife
- Tape Measure
- 50mm Hole-saw

STEP 3 - Unpack Mounting Platform:

Check the Contents of Each Kit

Mounting Platform 1400 Type A (IIG000782)

Part Name	Quantity
B302 Mounting Rail TG	2
B170 Platform Rail Bracket	5
B403 Mounting Rail End Cap Long	4

Fastener Pack - Mounting Platform 1400 (IIG002110 B0177)

Part Name	Quantity
M10 x 60 BtnHd Hex High Tensile Grade 12.9 ZN BK ISO7380	10
M10 Nut Torque SS304 DIN 985	10
10mm Washer Large SS304 DIN 9021	10
Spacer Disc 30mmOD x 20mm BK	10
Spacer Disc 30mmOD x 10mm BK	10

Catch-and-Click™ Kit (Contents per Kit)

Part Name	Quantity
B0092 Click Bracket Assembly	2
B0090 Catch Bracket Assembly	2
M6 Nut Conelock High Tensile Class 10 ZN DIN980	22
M6 x 12 CTSK High Tensile 12.9 ZN BK DIN7991	14
M6 x 30 CTSK High Tensile 12.9 ZN BK DIN7991	8

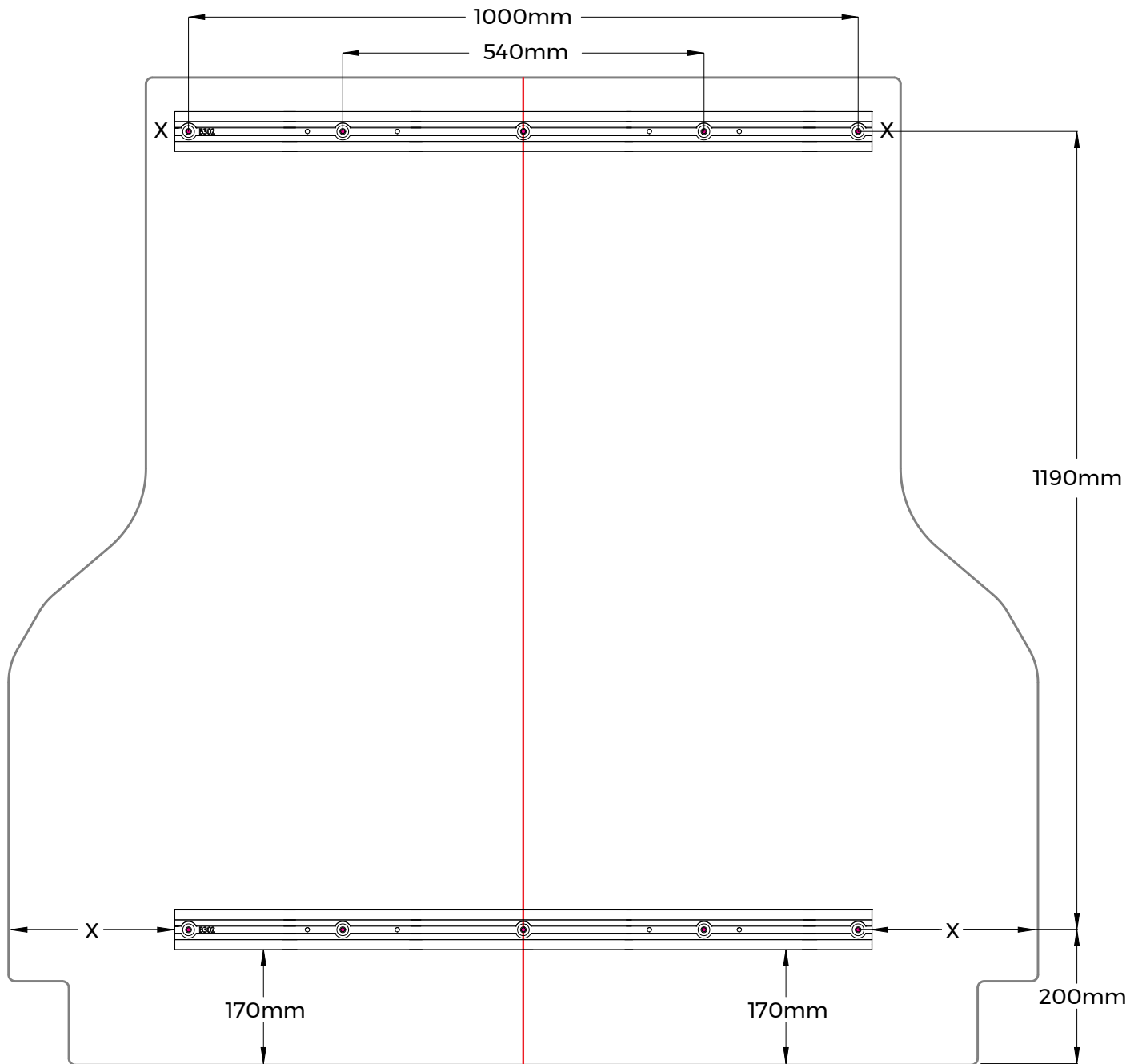

STEP 4 - Layout the Rails:

- Accurately measure and mark centerline of tub - **“Critical to successful fitment”**
- Position the forward B302 Rail (Tailgate end) 170mm from the inside of the closed tail gate and centred - measure X distances on either side to confirm the B302 rail is centred.
- Position the rearward B302 rail (Cabin end) 1190mm centre to centre of the rail M10 mounting holes and in centre of the tub using your marked centreline and measuring X distances on either side.
- Once the B302 Rails are in position, mark the 5 large M10 holes with a marker in preparation of drilling pilot holes.



NOTE: Check underneath the ute tub to avoid damaging critical vehicle components before drilling pilot holes or larger through holes.

STEP 5 - Drill the Pilot Hole Positions:

- Remove the B302 rails - make sure your marker in step 4 has marked the 5 x M10 hole positions.
- Drill a 3mm pilot hole in the marked positions X and Y shown diagram.

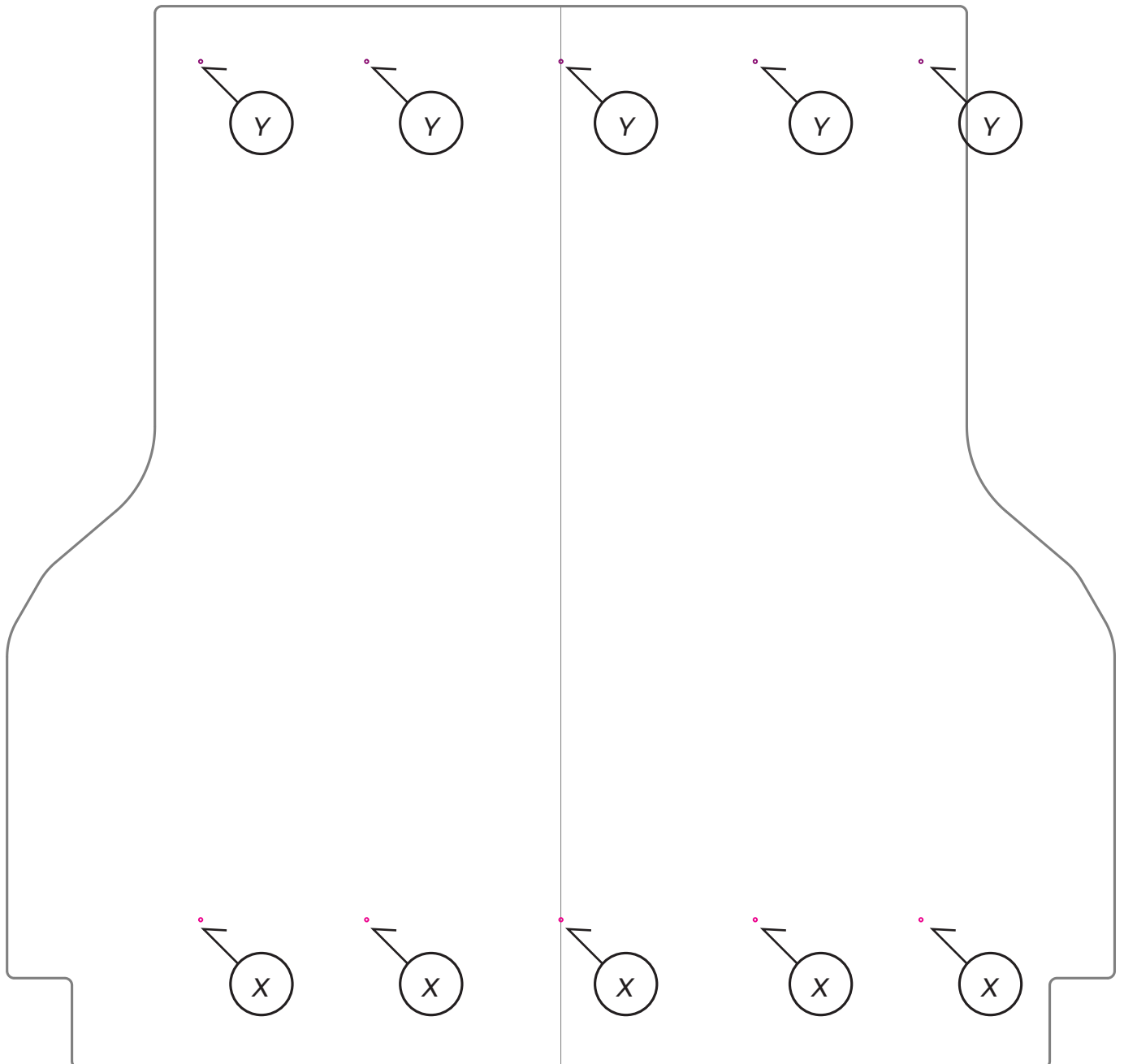

STEP 6 - Hole-Saw the Tub-liner:

- Saw 50mm holes through the Tub-liner material only at the pilot hole locations.
- **DO NOT** hole-saw the ute tub steel floor.

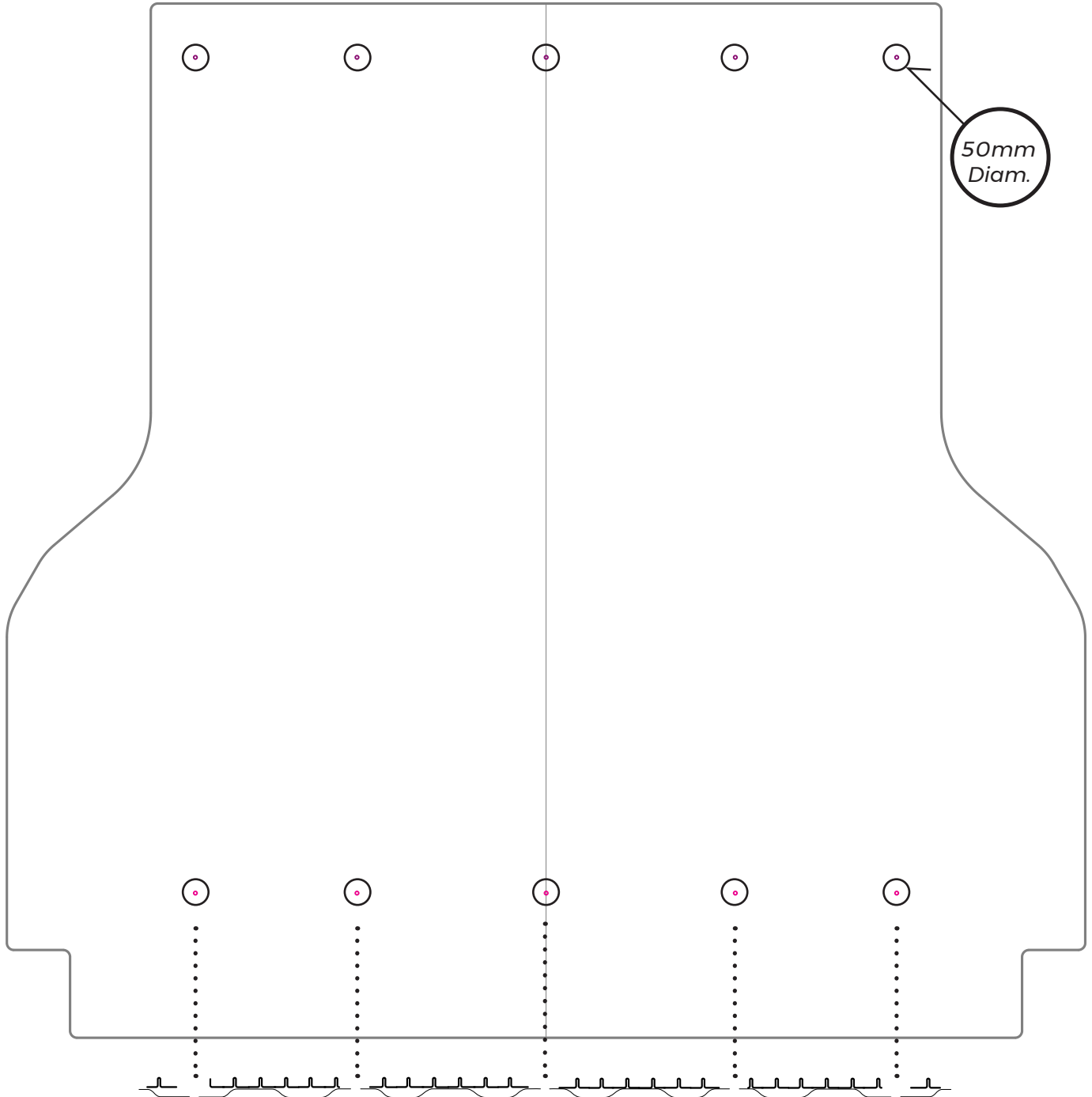

Example Cross Section View

NOTE: Aftermarket tub-liners can vary significantly between vehicles of the same model.

Step 6 continued on next page...

STEP 6 Continued - Hole-Saw the Tub-liner:

NOTE: Aftermarket tub-liners can vary significantly between vehicles of the same model.

The KUFU Mounting Platform is compatible to both Ribbed Tub-liner (Image 1) and Flat Tub-liner (Image 2), the KUFU Mounting platform should be securely attached to the steel floor of the ute tub.

Removing some of the Tub-liner material allows space needed to raise and level the Mounting Platform above different liner profiles. Follow this manual to remove the tub-liner around the bolt locations to allow for a level and safe installation.

- Use Spacer Disc parts provided to create a level installation in the next steps.



Image 1 : Ribbed Tub-liner.



Image 2 : Flat Tub-liner.

STEP 7 - Drill the through Holes:

NOTE: Check underneath the ute tub thoroughly to avoid damaging critical vehicle components before drilling holes.

- Drill a 10mm through hole in the pilot hole positions from previous step.

TIP: Use a step-drill instead of a twist drill bit if there is critical vehicle components beneath a hole position. A step-drill is shorter and will not protrude as far through the hole as a twist drill bit that can potentially cause damage.

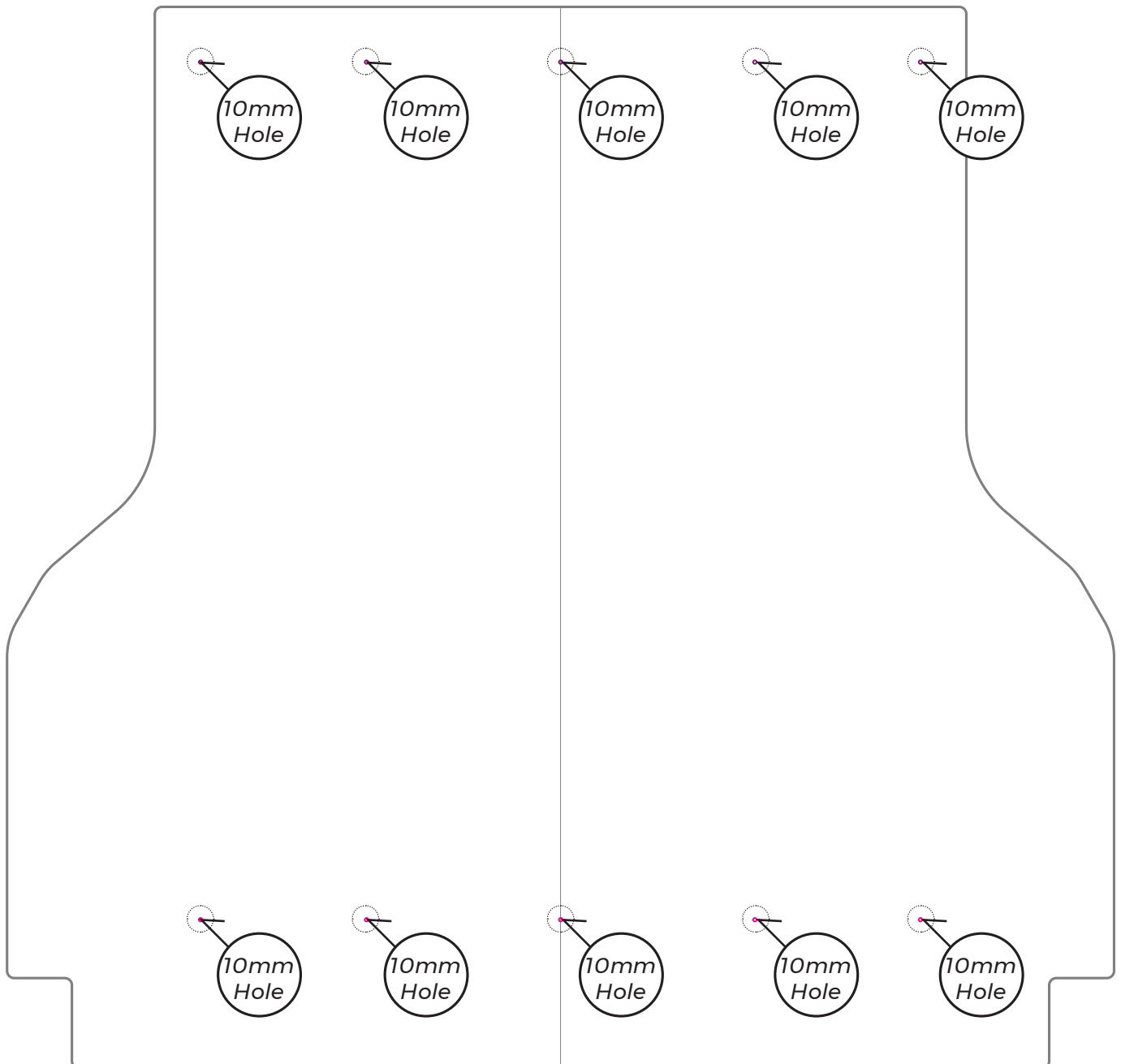

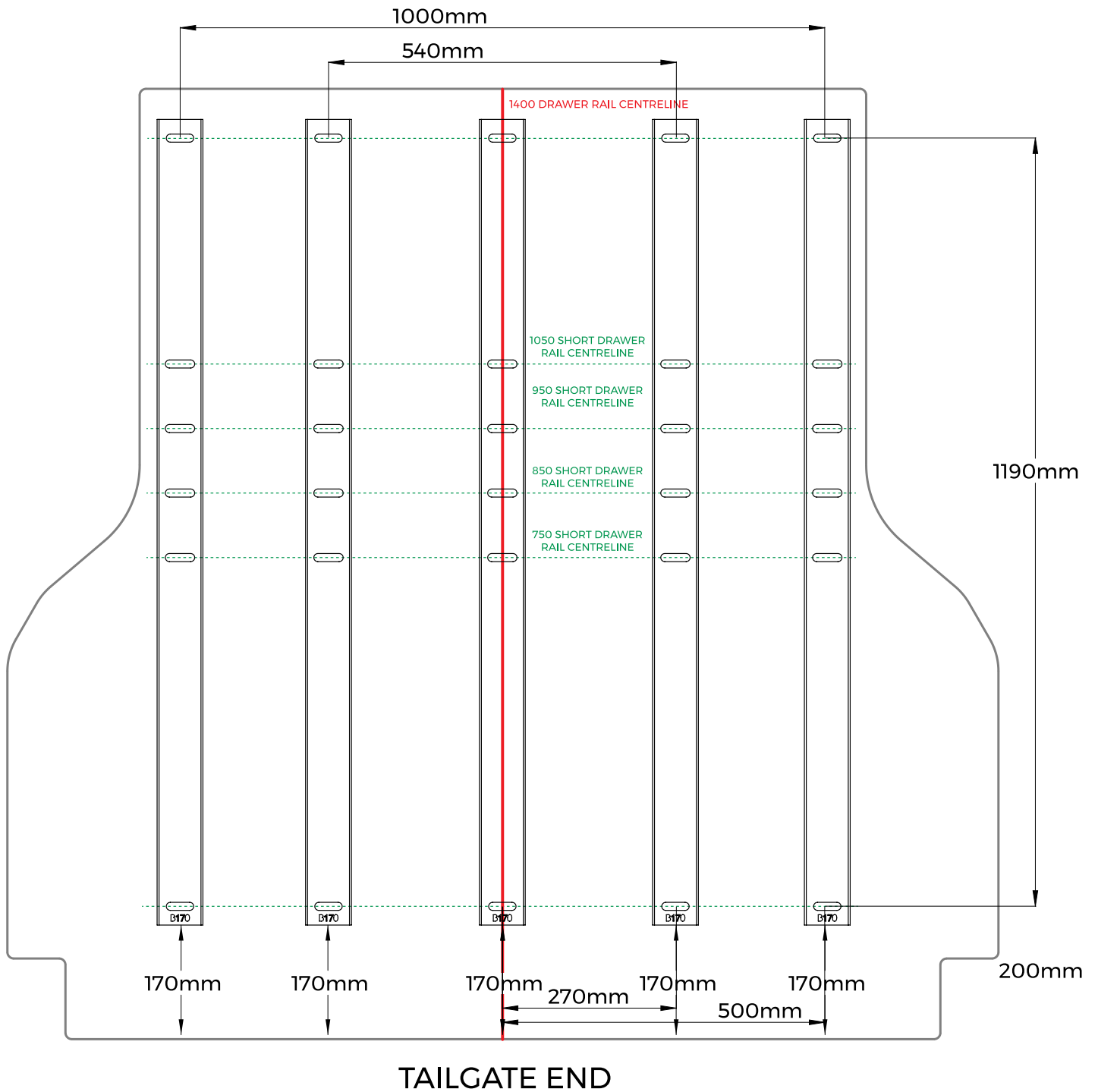

STEP 8 - Layout the Rails:

- Layout and position the B170 rails, make sure the CNC CUT B170 in the rails are at the tailgate end over the drilled 10mm holes. (as shown)

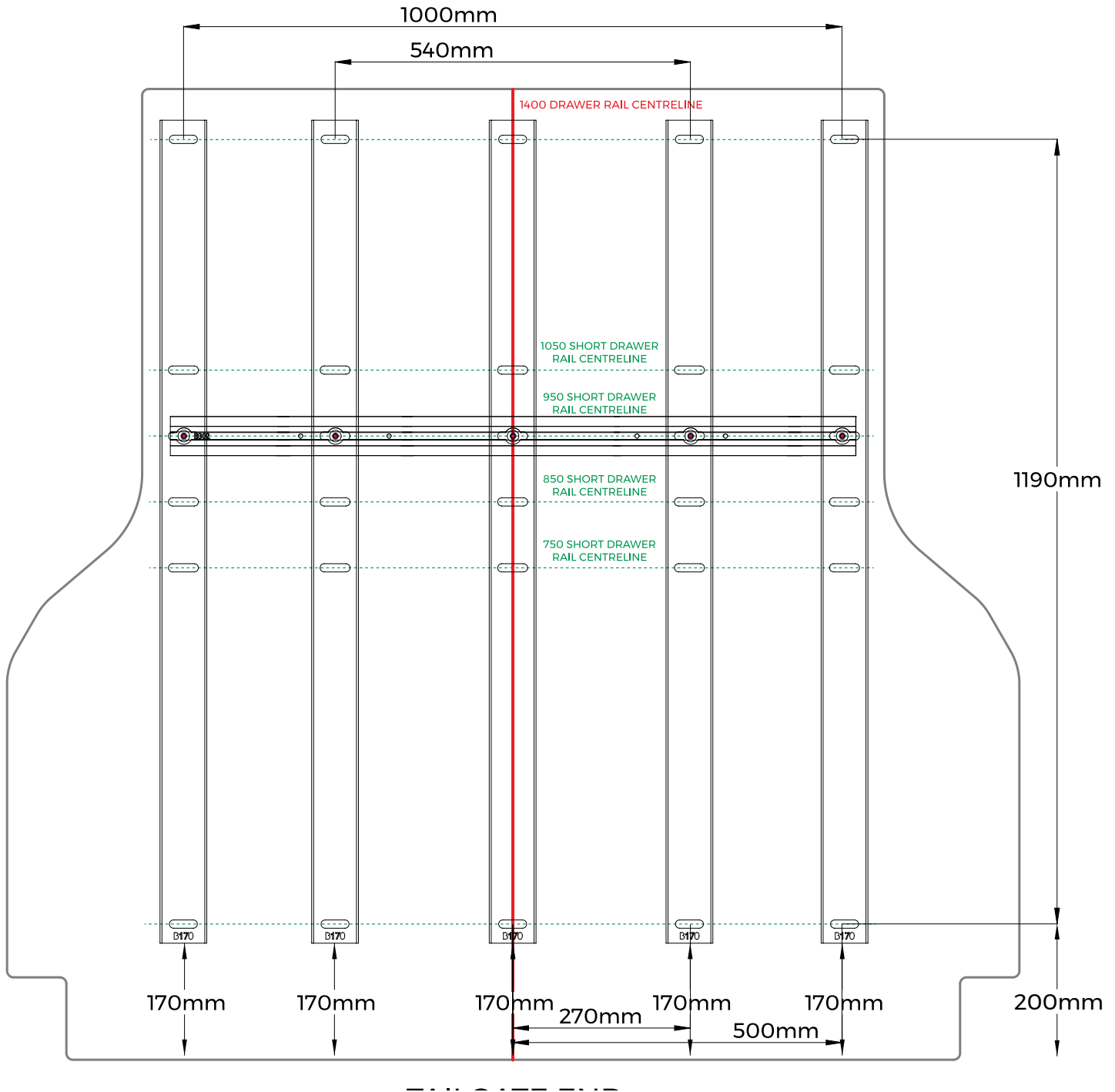

ADDED STEP IF INSTALLING TWIN SHORT DRAWERS ON A 1400 MOUNTING PLATFORM:

- Short Drawer Rail Layout for Reference:
- Locate the correct short drawer rail mounting points on the B170 rails
- The location points starting from the tail gate end are to fit short drawers – 750mm, 850mm 950mm (B302 Rail shown in position) and 1050mm drawer lengths.
- Installing the B302 Rail requires position the rail, marking the 5 x M10 holes and following steps 5, 6, 7 and 9 to complete the installation.
- The rearward (Cabin end) B302 will not have the Catch Brackets installed, these will now be installed on the Short Drawer Rail B302.

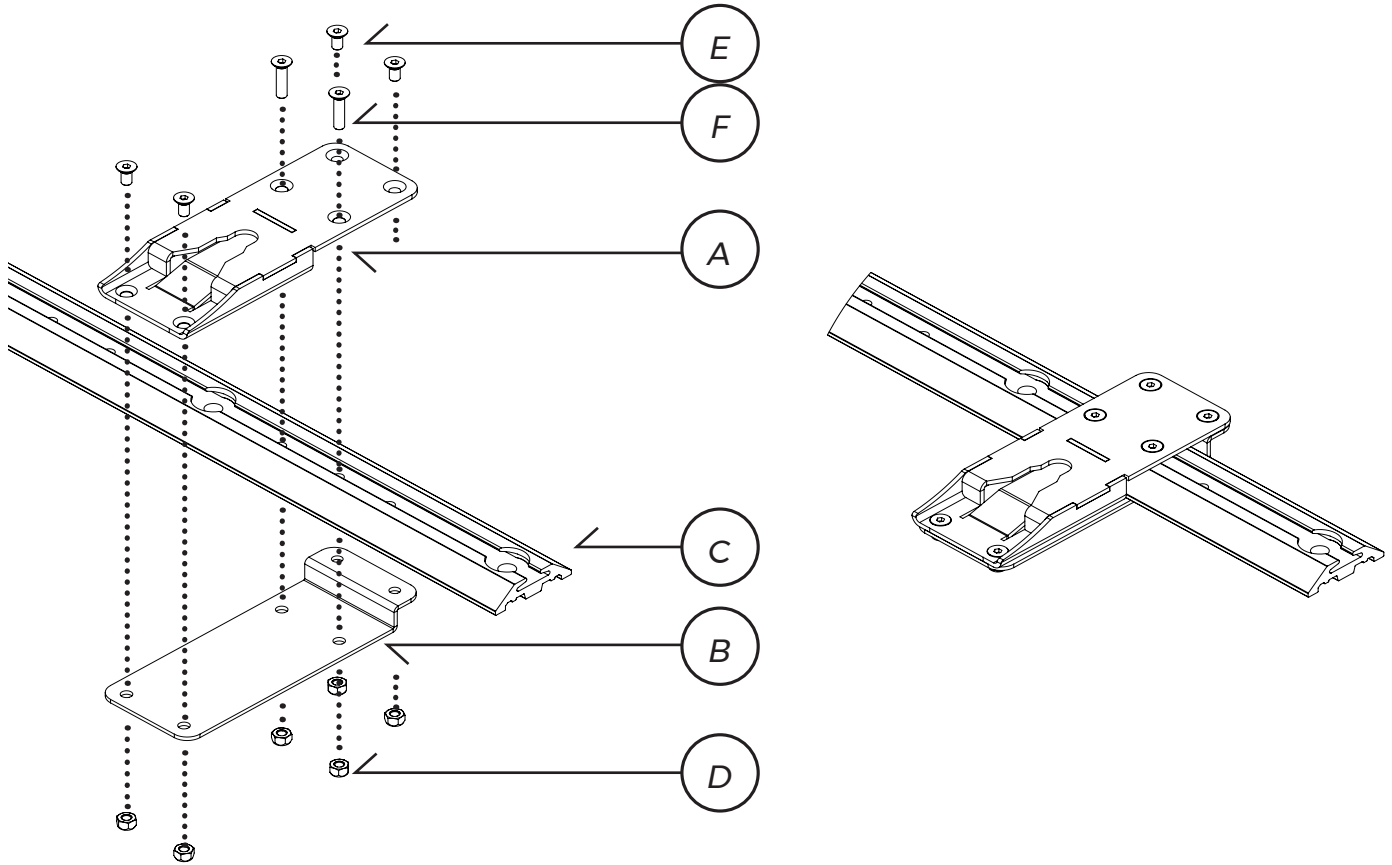

STEP 9 - Catch Brackets Assembly:

- Securely Assemble the Catch Brackets to the B302 Rail
- Catch Bracket, Single Assembly shown above in exploded view.

Part Name	Quantity	Item
Catch Bracket, Upper	1	A
Catch Bracket, Lower	1	B
B302 Rail	1	C
M6 Nut Conelock High Tensile Class 10 ZN DIN980	6	D
M6 x 12 CTSK High Tensile 12.9 ZN BK DIN7991	4	E
M6 x 30 CTSK High Tensile 12.9 ZN BK DIN7991	2	F

- Check and ensure all brackets are 90degrees to the rail.
- Tighten the Catch Bracket Assembly in all positions shown below. Use hand tools to securely tighten all fasteners.

NOTE: The Catch Brackets use 2 of 3 holes along the rail in each position, note the remaining holes as a guide of the Catch Bracket positions.

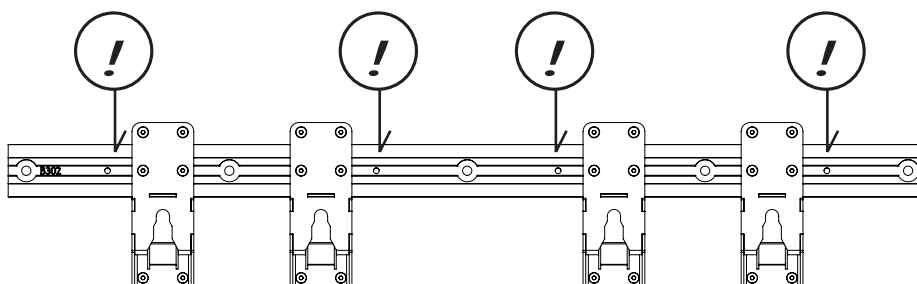

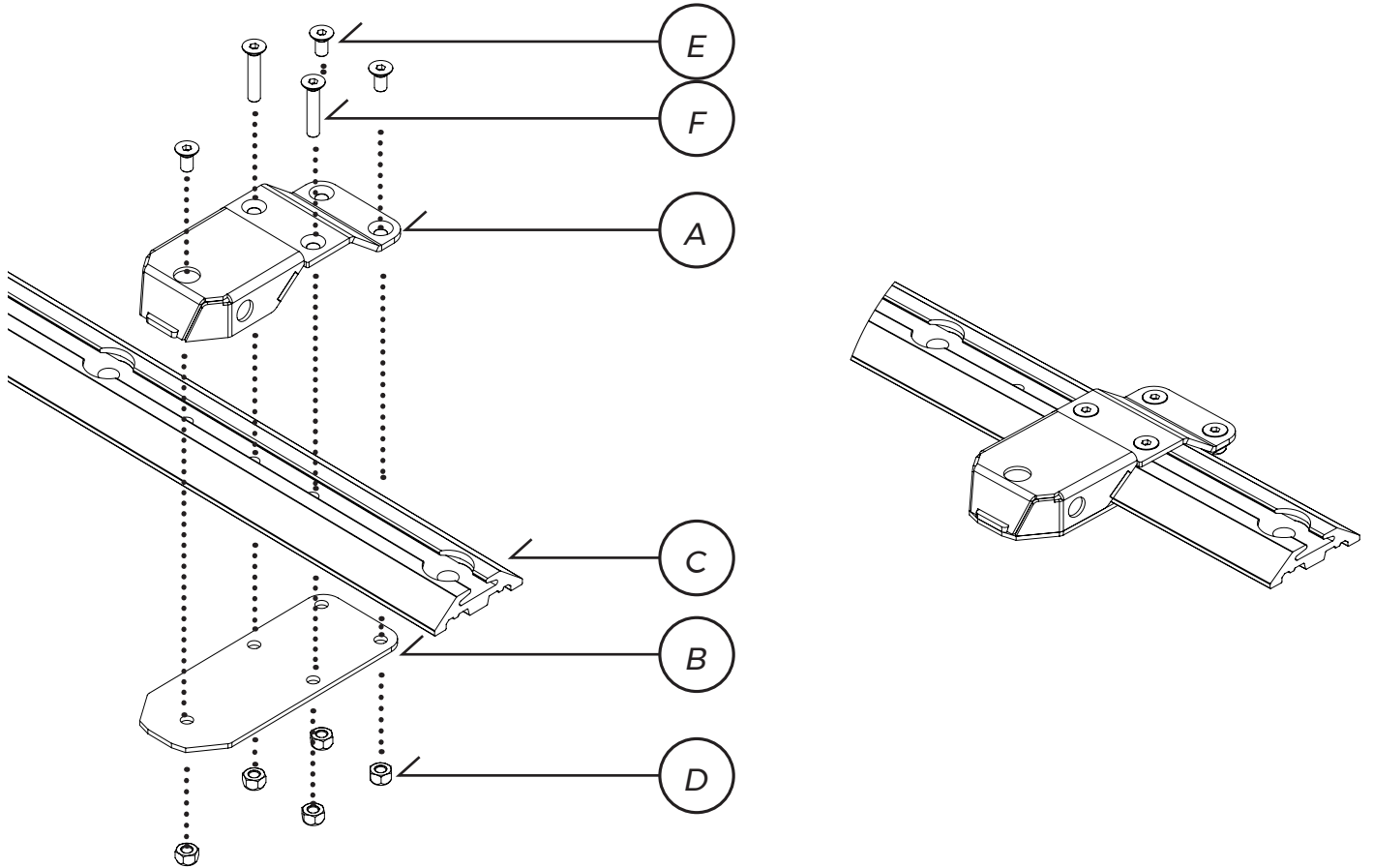

STEP 10 - Click Brackets Assembly:

- Securely Assemble the Click Brackets to the B302 Rail
- Catch Bracket, Single Assembly shown above in exploded view.

Part Name	Quantity	Item
Click Bracket, Upper	1	A
Click Bracket, Lower	1	B
B302 Rail	1	C
M6 Nut Conelock High Tensile Class 10 ZN DIN980	5	D
M6 x 12 CTSK High Tensile 12.9 ZN BK DIN7991	3	E
M6 x 30 CTSK High Tensile 12.9 ZN BK DIN7991	2	F

- Check and ensure all brackets are 90degrees to the rail.
- Tighten the Click Bracket Assembly in all positions shown below. Use hand tools to securely tighten all fasteners.

NOTE: The Click Brackets use 2 of 3 holes along the rail in each position, note the remaining holes as a guide of the Click Bracket positions.

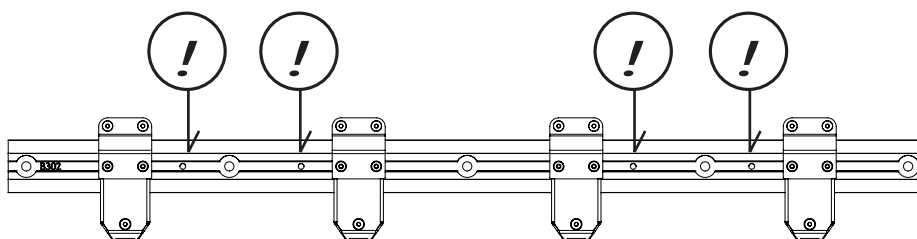

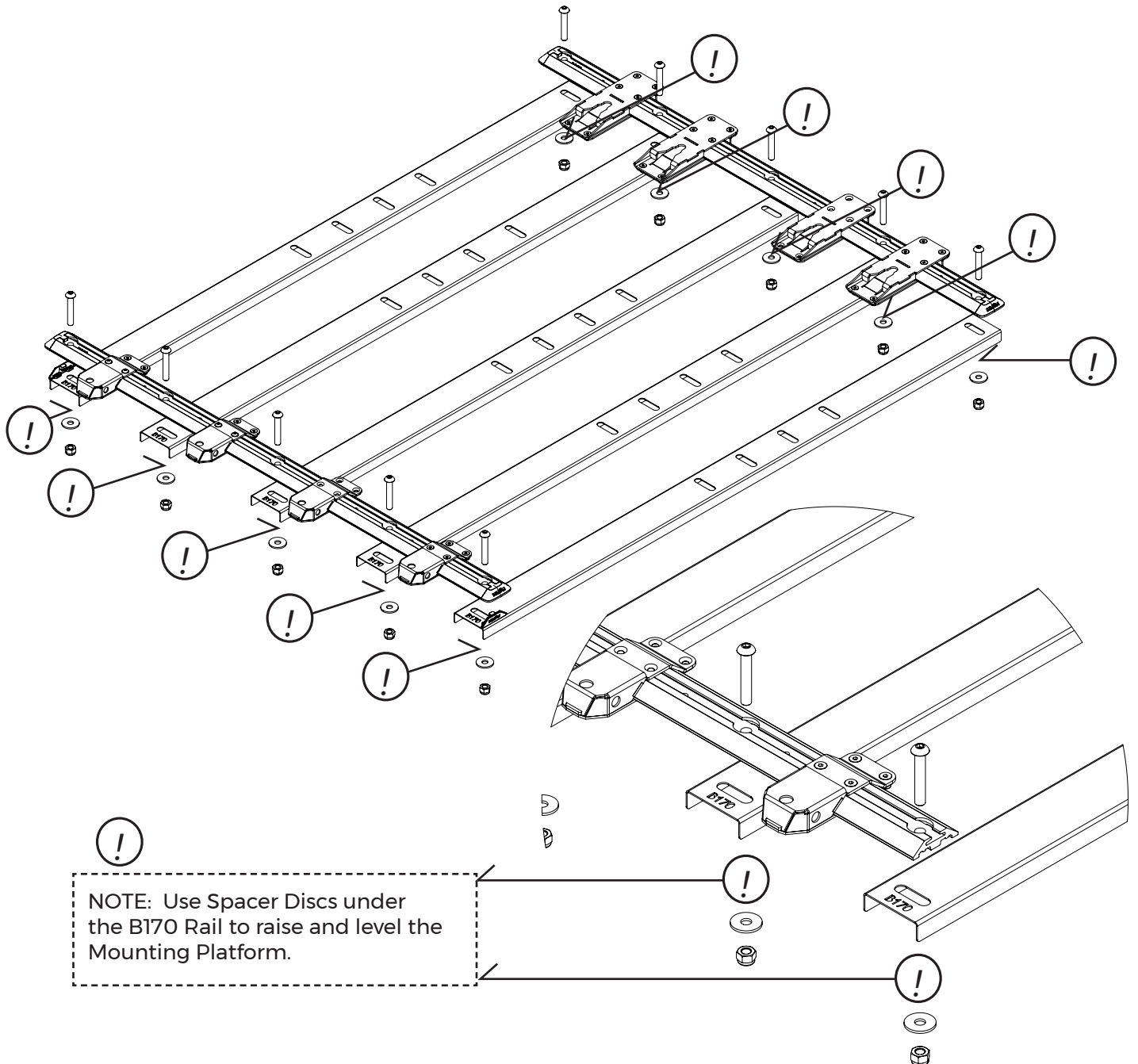

STEP 11 - Secure the 1400 Mounting Platform to the Ute Bed:

- Position the Click Brackets and Rail assembly above the tailgate end of the B170 Rails.
- Locate the position with 5x M10 Bolts into the 10mm through holes.
- Position the Catch Brackets and Rail assembly above the cabin or forward end of the B170 Rails.
- Locate the position with 5x M10 Bolts into the 10mm through holes.
- Use Spacer Discs under the B170 Rails to level the Mounting Platform.

NOTE: If you find a variance that requires a smaller size spacer, than the supplied 10mm and 20mm Spacers, the spacers are easily cut with a hacksaw or you can adjust with M10 x 30mm washers, due to variations and in some cases tub floor damage, it is necessary to source washers or modify spacers.

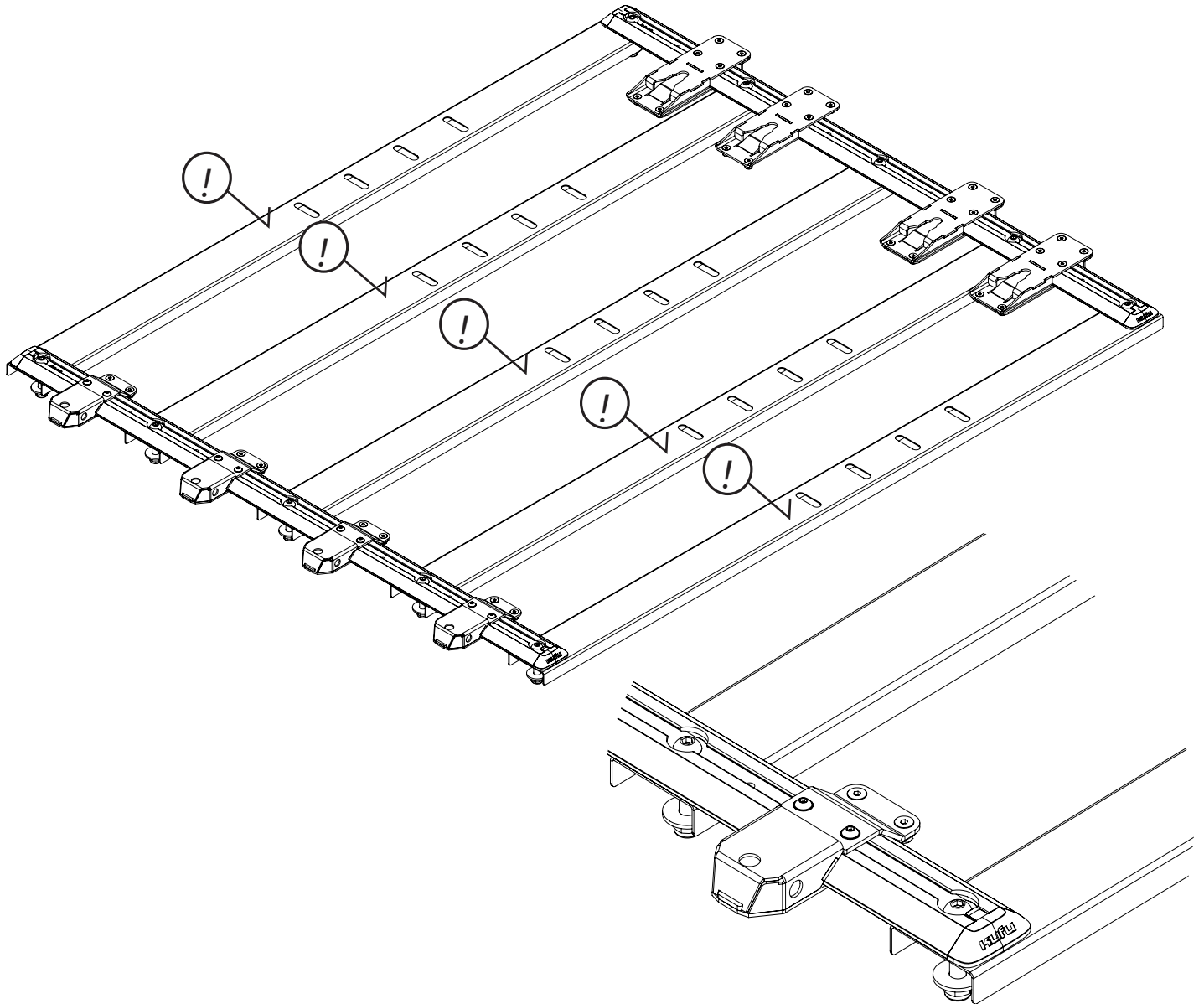

STEP 12 - Fasten the 1400 Mounting Platform to the Ute Bed:

- Apply Washers and M10 Lock Nuts to the M10 Bolts
- Securely tighten the fasteners using hand tools.
- Do not overtighten. Stop before damaging or crushing the vehicle

TIP: Check if the assembly requires Spacer Discs that prevent crushing or damage.



NOTE: B170 Rail should not bow or buckle or curve after tightening of fasteners. The B170 Rails should remain flat to allow the secure and reliable attachment of the KUFU Drawer System. Check to ensure the Tub-liner does not interfere with rails and is not causing the rails to bend or curve.

STEP 13 - Check the Level :

- Ensure the Catch Rail Assembly and Click Rail Assembly are level across the floor of the vehicle.



NOTE: Some bolt down positions may require extra-stacked Spacer Discs to make the assembly level. See Example Cross Section View below.

NOTE: If you find a variance that requires a smaller size spacer, than the supplied 10mm and 20mm Spacers, the spacers are easily cut with a hacksaw or you can adjust with M10 x 30mm washers, due to variations and in some cases tub floor damage, it is necessary to source washers or modify spacers.

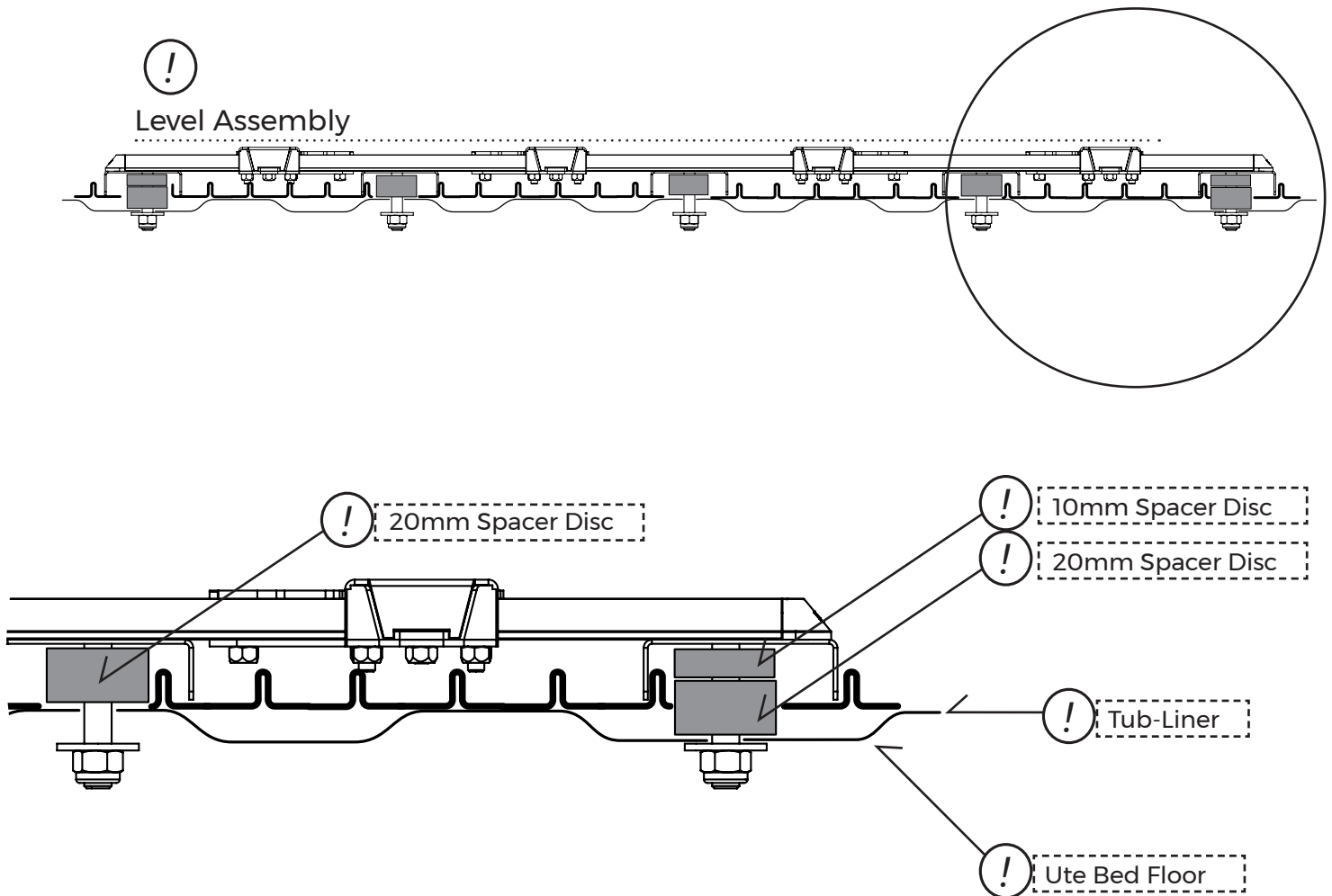

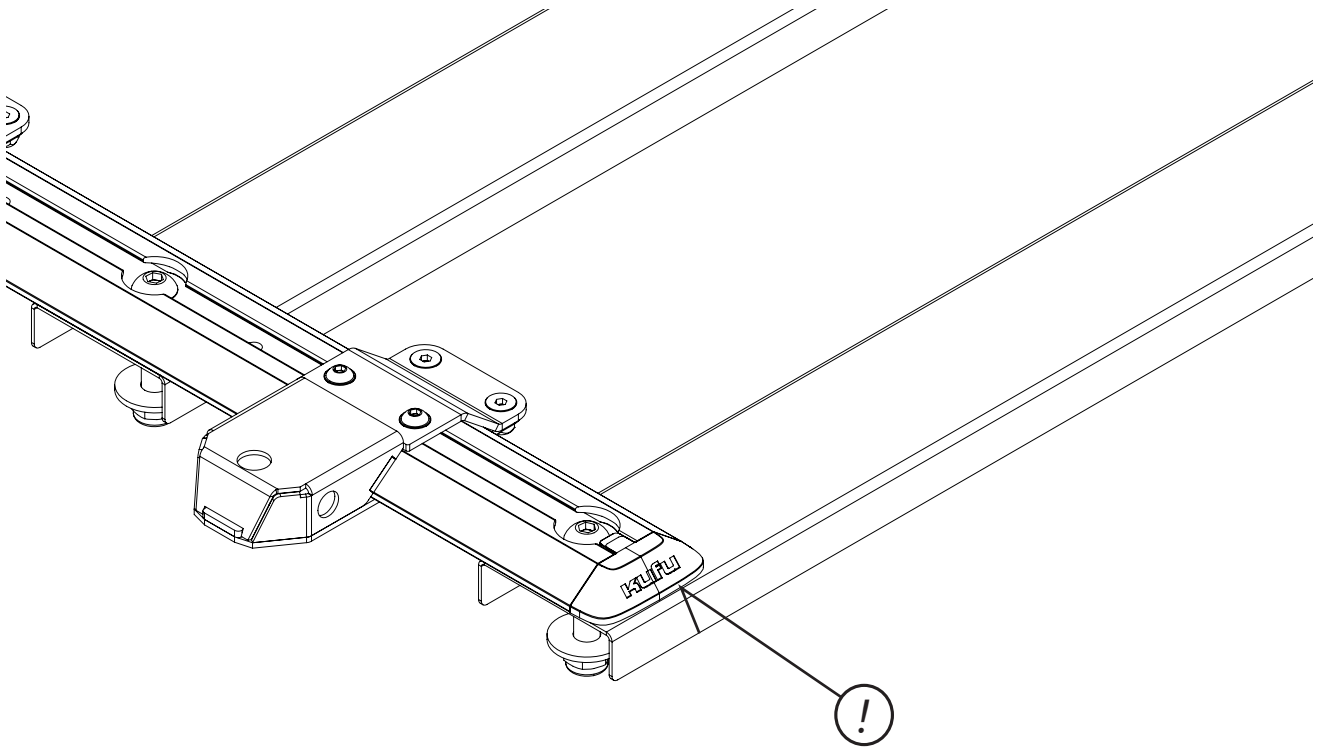

STEP 14 - Assemble End Caps:

- Assemble the End Caps x4 positions.

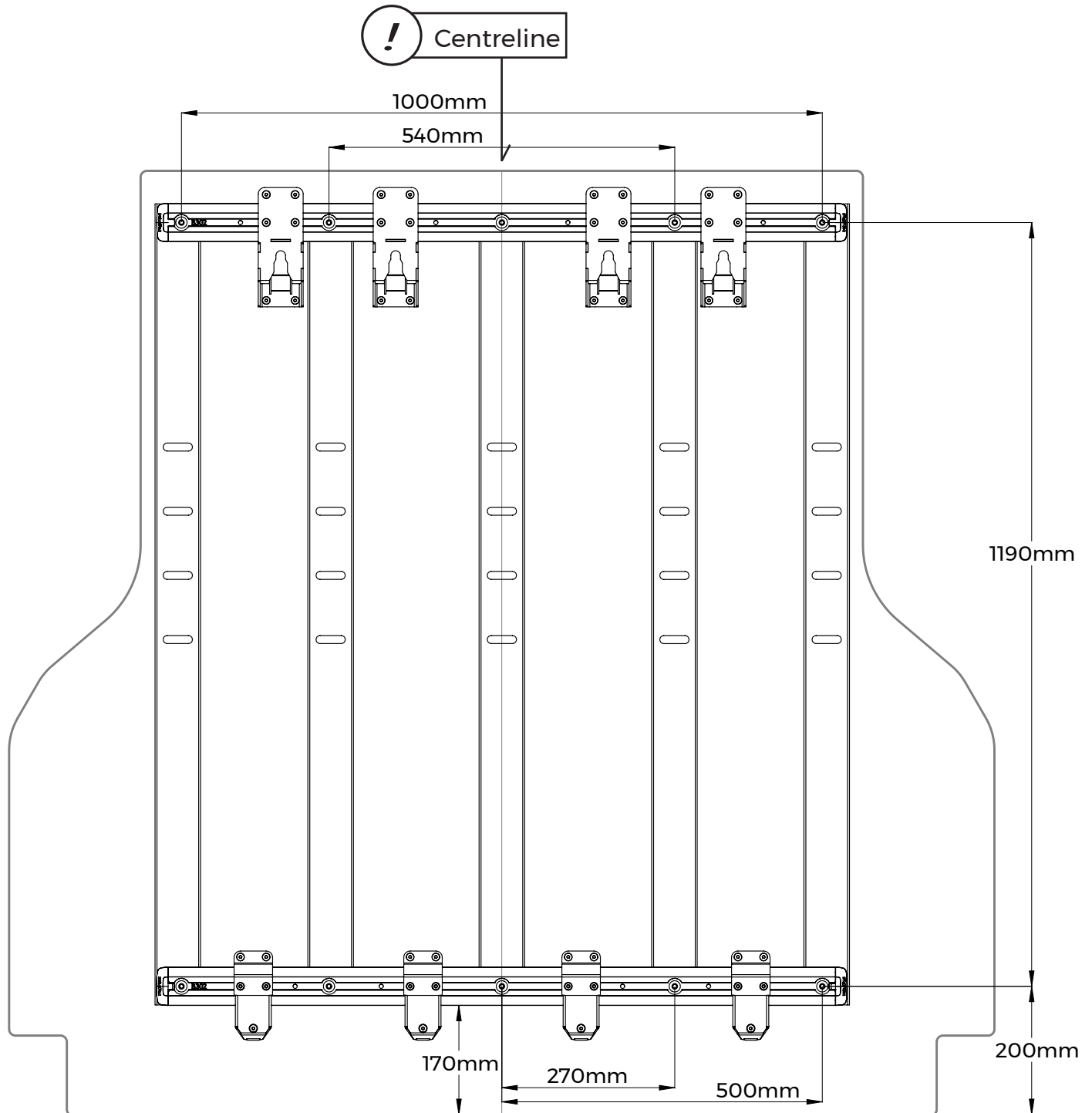

STEP 15 - Layout for Reference:

- Above is a plan view layout of the finished assembly for reference.
- The assembly is shown in a vehicle ute / truck bed outline for reference.
- Note the centreline of the vehicle aligns with the centre of the 1400 Mounting Platform.
- There is additional space allowed at the tailgate of the ute bed for the installation of the drawer system and clearance for the closing tailgate.



KUFU Drawer System

Designed and developed in Australia.
Australia Owned Certified #08416.

www.umhauer.com.au/kufu
sales@umhauer.com.au

Umhauer Products Australia
Rear of 153 Ash Road
Leopold VIC 3224 Australia

Design Registrations

AU 202110927, 202110924, 202110925, 202110926
EU 008654297-0001, 008654297-0002, 008654297-0003, 008654297-0004
UK 6175068, 6175069, 6175070, 6175071

Patents Pending

AU 2022201080, 2022201079
US 17/677,178

Patents

US 12,286,080, US D1,039,470 S, US D1,032,485 S, US D1,032,484 S, US D1,032,486 S
EU 4046872, 4063195

JULY 2025